

FEATURED PRODUCT - SERIES JBW



JBW MODEL TABLE

MODEL	OUTPUT	SETTING TOLERANCE	OVP	OUTPUT	CURRENT	SW RIPPLE	NOISE	EFFICIENCY (%) ⁽³⁾		LOAD CAPACITANCE ⁽⁴⁾
	Volts		SETTING	CURRENT	LIMIT	(mV p-p)	(mV p-p)	100V a-c	240V a-c	
10 WATT MODELS										
JBW 03-2R0	3.3	±0.25V	3.75	2	2.5	80	120	69	69	10000µF
JBW 05-2R0	5	±0.25V	5.75	2	2.5	80	120	71	71	10000µF
JBW 12-0R9	12	±0.6V	13.8	0.9	1.12	120	150	78	79	5000µF
JBW 15-0R7	15	±0.75V	17.25	0.7	0.87	120	150	79	80	4000µF
JBW 24-0R5	24	±1.2V	27.6	0.5	0.62	120	150	82	83	2000µF
15 WATT MODELS										
JBW 05-3R0	5	±0.25V	5.75	3	3.15	80	120	72	72	10000µF
JBW 12-1R3	12	±0.6V	13.8	1.3	1.37	120	150	74	74	5000µF
JBW 15-1R0	15	±0.75V	17.25	1	1.05	120	150	74	74	4000µF
JBW 24-0R7	24	±1.2V	27.6	0.7	0.74	120	150	76	76	2000µF
30 WATT MODELS										
JBW 05-6R0	5	±0.25V	5.6	6	6.3	80	120	75	77	10000µF
JBW 12-2R5	12	±0.6V	13.3	2.5	2.7	120	150	78	79	5200µF
JBW 15-2R0	15	±0.75V	16.6	2	2.1	120	150	79	80	4000µF
JBW 24-1R3	24	±1.2V	26.5	1.3	1.4	120	150	80	81	1000µF

- (1) Still air rating -10 to +50°C. Derate 30% at 60°C. Consult factory for increased ratings with moving air.
 (2) Minimum, consult factory.
 (3) Typical.
 (4) Acceptable added output capacitance, max.
 (5) Overvoltage protection for the 10 and 15W models comprises a zener diode across the output to limit voltage. Overvoltage in the 30W models is provided by a shut-down circuit.



CompuMess Elektronik GmbH • Lise-Meitner-Str.1 • 85716 Unterschleissheim
 Tel 089-321501-0 • Fax 089-321501-11 • www.compumess.de • www.netzteile.de

JBW INPUT CHARACTERISTICS

SPECIFICATION		10 WATT MODELS	15 WATT MODELS	30 WATT MODELS	CONDITION
a-c Voltage	nom	100-240V a-c			0-100% load, -10 to +60°C
	range	85-265V a-c			
d-c Voltage	range	110-370V d-c			
		Note: safety recognition for a-c only			
Frequency	range	47-440Hz			
Current	100V a-c	0.25A typ	0.36A typ	0.65A typ	
	240V a-c	0.15A typ	0.20A typ	0.35A typ	
EMI	conducted	FCC Class B VCCI-B EN55011-B EN55022-B			
Leakage Current	100V a-c	0.75mA max 0.1mA typ	0.75mA max 0.2mA typ	0.75mA max 0.35mA typ	at 60Hz
	240V a-c	0.75mA max 0.15mA typ	0.75mA max 0.3mA typ	0.75mA max 0.35mA typ	
Holdup Time	100V a-c	15msec typ	13msec typ	20msec typ	
	240V a-c	140msec typ	150msec typ	160msec typ	
Surge Current	100V a-c	20A max 15A typ	19.5A max 15A typ	30A max 15A typ	
	240V a-c	40A max 30A typ	41A max 30A typ	60A max 30A typ	
Power Factor	100V a-c	0.6 typ			
	240V a-c	0.45 typ			
Switching Frequency		100KHz typ	Variable with load	66KHz typ	
Input Fuse		2A/250V a-c			

JBW OUTPUT CHARACTERISTICS

SPECIFICATION		10 WATT MODELS	15 WATT MODELS	30 WATT MODELS	CONDITION
Source Effect	max	0.40%			85-265V a-c
Load Effect	max	0.80%			0-100% load
Temperature Effect	max	1%		2%	-10 to +50°C
Time Effect	max	0.40%			0.5-8 hours
Transient excursion Recovery		±4%			50-100% load, >50µsec rise -10 to 50°C
Start Up Time	100V a-c	700msec max, 200msec typ	200msec max, 25msec typ	650msec max, 350msec typ	See note (1)
	240V a-c	700msec max, 200msec typ	100msec max, 25msec typ	320msec max, 130msec typ	See note (2)

- (1) The 15W size, 15V and 24V models: 200msec max, 40msec typ for 100V a-c input.
 (2) The 15W size, 15V and 24V models: 100msec max, 40msec typ for 240V a-c input.

FIGURE 1
Output Power
vs.
Ambient Temperature

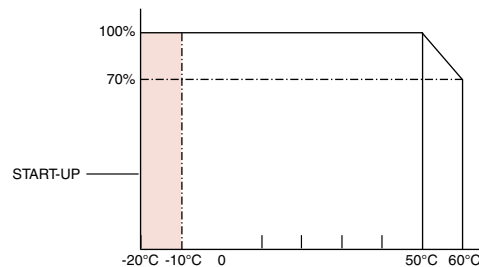

The Kepco/TDK JBW series are comprised of three groups of affordable power supplies: 10W, 15W and 30W in a PC-card style. They offer fixed output voltages from 3.3V d-c to 24V d-c for space and cost sensitive OEMs. They operate from any a-c mains in the range 85-265V a-c or a d-c input in the range 110-370V d-c.

JBW are fitted with input filters that suppress conducted emissions below the requirements of FCC Class B, VCCI B, EN55011-B and EN55022-B. A flyback converter is used for high efficiency approaching 80 percent. The low profile and small footprint of the JBW power supplies will allow them to fit into tight quarters.

JBW are recognized to UL 1950-3, CSA22.2 No. 950-95 and EN60950. They bear the CE mark for use in the European Community. JBW are ideal for cost sensitive OEM applications that require a quality small power supply with all international and safety certifications.



CE JBW are CE marked per the Low Voltage Directive (LVD), EN60950.

JBW can be combined into a custom power assembly for multi-output requirements. Please see pages 131-135 for details on Kepco's Power Assembly Program.



JBW INPUT / OUTPUT CABLE KITS

For 10W and 15W Models – Kit 219-0406
 For 30W Models – Kit 219-0408

JBW INPUT / OUTPUT CONNECTORS

	MFRS.	POWER SUPPLY END	SOCKET HOUSING	TERMINAL PIN
For 10W and 15W Models				
Input	JST LCE	B3P5-VH-B P101-05-2/4	VHR-5N H101-05	SVH-21T-P1.1 T101
Output	JST LCE	B4B-XH-2 P221-04	XHP-4 H221-04	SXH-001T-P0.6 T221-01
For 30W Models				
Input	JST LCE	B3P5-VH-B P101-05-2/4	VHR-5N H101-05	SVH-21T-P1.1 T101
Output	JST LCE	B4B-VH-B P101-04	VHR-4N H101-04	SVH-21T-P1.1 T101

JST: Japan Solderless Terminal Mfg. Co., Ltd.
 LCE: Long Chu Electronics Co., Ltd.

OUTLINE DIMENSIONAL DRAWINGS

Fractional dimensions in light face type are in inches, dimensions in bold face type are in millimeters.

Mount on 8mm (minimum) standoffs and, for safety reasons, provide a minimum of 4mm clearance above the components on the top of the PC card.

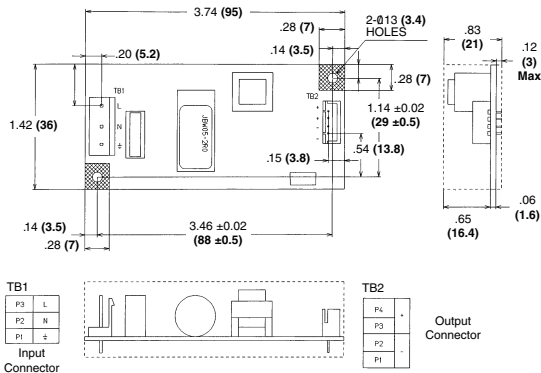

10W JBW

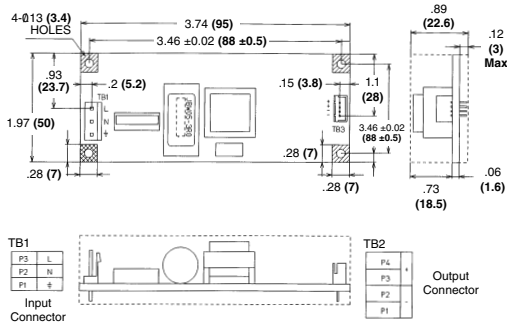

15W JBW

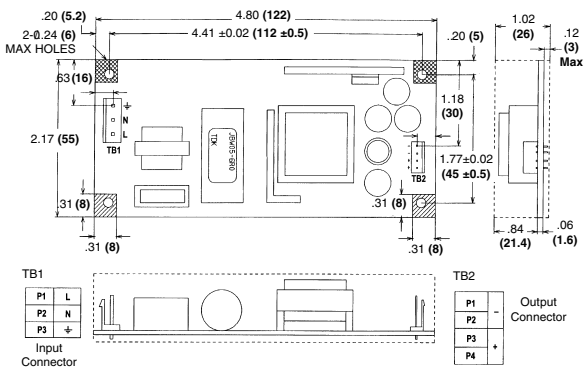

30W JBW

JBW GENERAL/ENVIRONMENTAL SPECIFICATIONS

SPECIFICATION		RATING/DESCRIPTION	CONDITION
Temperature	Operating	-10 to +60°C (1)	
	Start up	-20 to +60°C	
	Storage	-30 to +75°C	
Humidity		20 to 90% RH	Wet bulb temperature <35°C
Vibration	5-10Hz	10mm amplitude	Sweep time 10 min. 1 hr ea axis (2)
	10-200Hz	19.6 m/s ² (2g) acceleration	
Shock	Acceleration	588 m/s ² (60g) 1/2 sine pulse	3 shocks ea axis (2)
	Duration	11 ±5 msec	
Incoming Noise	input-input	2kV pulse, 1µs	Normal operation (50Ω termination)
	input-ground	2kV pulse, 1µs	50-60Hz(3)
Surge Withstand	input-input	3kV pulse, 1.2 x 50µsec	100Ω internal series resistor (3)
	input-ground		
Immunity from Electrostatic Discharge		10kV from charged capacitor	Ground potential area-ground C=500 pF, 100Ω series res
Safety Standards		UL1950-3; CSA22.2 No. 950-95; EN60950	Ambient temperature 50°C max. a-c input only
Conducted EMI		FCC Class B, VCCI-B; EN55011-B; EN55022-B	
Withstand Voltage	input-output	a-c 3000V, 1min (cutout 10mA)	5-35°C, 45-85% RH
	input-ground	a-c 2000V, 1min (cutout 10mA)	
	output-ground	a-c 500V, 1min (cutout 10mA)	
Insulation Resistance	input-output	>100 MΩ (d-c 500V)	5-35°C, 45-85% RH
	input-ground		
	output-ground		
Dimensions	10W English	0.83" x 1.42" x 3.74"	See outline drawings
	10W Metric	21mm x 36mm x 95mm	
	15W English	0.89" x 1.97" x 3.74"	
	15W Metric	22.6mm x 50mm x 95mm	
	30W Metric	26mm x 50mm x 122mm	
Cooling		Natural convection	

- 1) Full output power in still air to +50°C. Derate 30% for still air operation to +60°C. Consult factory for power ratings with moving air.
- (2) Non-operating.
- (3) Operating.



CompuMess Elektronik GmbH • Lise-Meitner-Str.1 • 85716 Unterschleissheim
Tel 089-321501-0 • Fax 089-321501-11 • www.compumess.de • www.netzteile.de