

MPL-03SEUP Series

Open, Single Output, Ultra-Miniature SIP, 3W AC/DC Power Supplies

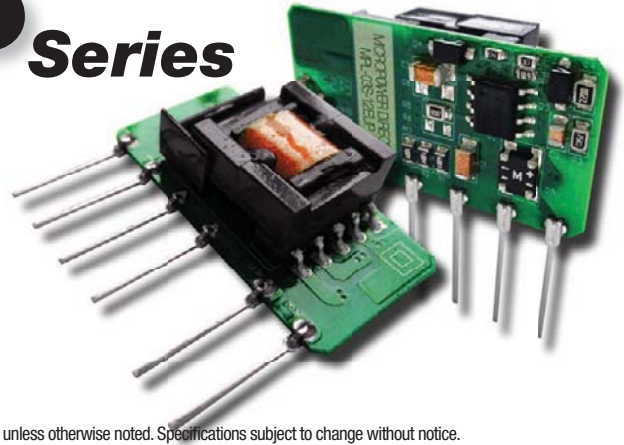

Key Features:

- 3W Output Power
- Open, Ultra-Miniature SIP
- Universal 85-264 VAC Input
- EN 60950 Approved
- Meets IEC Safety Class II
- Single Regulated Output
- Meets EN 55022 Class A
- >300 kHour MTBF
- **Low, Low Cost!**



RoHS



MicroPower Direct



Electrical Specifications

Specifications typical @ +25°C, 230 VAC input voltage & rated output current, unless otherwise noted. Specifications subject to change without notice.

Input

Parameter	Conditions	Min.	Typ.	Max.	Units
Input Voltage Range		85		264	VAC
		70		400	VDC
Input Frequency		47		440	Hz
Input Current	See Model Selection Guide				
Inrush Current	115 VAC		13.0		A Pk
	230 VAC		23.0		

Output

Parameter	Conditions	Min.	Typ.	Max.	Units
Output Voltage Accuracy	See Model Selection Guide				
Standby Power Consumption				0.5	W
Line Regulation	V _{IN} = MIN to MAX		±1.5		%
Load Regulation	I _{OUT} = 10% to 100%		±2.5		%
Ripple & Noise (20 MHz)	3.3, 5 V _{OUT} Models		70	150	mV P-P
	All Other Models		50	150	
Hold-Up Time	115 VAC	20			msec
	230 VAC	80			
Temperature Coefficient			±0.02		%/°C
Over Current Protection		110		140	%I _{OUT}
Short Circuit Protection	Continuous (Autorecovery)				

General

Parameter	Conditions	Min.	Typ.	Max.	Units
Isolation Voltage	Input to Output	3,000			VAC
Isolation Resistance	500 VDC	100			MΩ
Switching Frequency				60	kHz

EMI Characteristics

Parameter	Standard	Min.	Typ.	Max.	Units
Radiated Emissions	See Note 2 EN 55022				Class A
Conducted Emissions	See Note 2 EN 55022				Class A
ESD	EN 61000-4-2				Criteria B; ±4 kV Contact
RS	See Note 3 EN 61000-4-3				Criteria A; 10V/m
	See Note 4 EN 61000-4-4				Criteria B; ±2 kV
EFT	See Note 4 EN 61000-4-4				Criteria B; ±4 kV
Surge	See Note 5 EN 61000-4-5				Criteria B; ±1 kV / ±2 kV
CS	See Note 6 EN 61000-4-6				Criteria A; 3 Vrms
PFM	EN 61000-4-8				Criteria A; 10A/m
Voltage Dips	EN 61000-4-11				Criteria B; 0% - 70%

Environmental

Parameter	Conditions	Min.	Typ.	Max.	Units
Operating Temperature Range	Ambient	-40	+25	+85	°C
Storage Temperature Range		-40		+105	°C
Cooling	Free Air Convection (See Derating Curve)				
Humidity	RH, Non-condensing			85	%

Physical

Case Size	See Mechanical Drawing (Page 4)				
Case Material	Conformal Coating (UL94-V0)				
Weight					0.24 Oz (7g)
Solder Temperature	Wave Soldering (5 - 10s)	255	260	265	°C
	Manual Soldering (3 - 5s)	350	360	370	

Reliability Specifications

Parameter	Conditions	Min.	Typ.	Max.	Units
MTBF	MIL HDBK 217F, 25°C, Gnd Benign	300			kHours
Safety Standards	UL 60950, EN 60950				
Safety Class	IEC 61140 Class II				

Model Selection Guide

Model Number	Input		Output		Maximum Output Power (W)	Output Voltage Accuracy (%)	Capacitive Load (µF, Max)	Efficiency (% Typ)	Fuse Rating Slow-Blow
	Current (A Max.)		Voltage (VDC)	Current (mA Max.)					
	115 VAC	230 VAC							
MPL-03S-03EUP	0.120	0.060	3.3	500	1.65	±3.0	470	63	1.0A/250 VAC
MPL-03S-05EUP	0.120	0.060	5.0	500	2.50	±5.0	470	68	1.0A/250 VAC
MPL-03S-09EUP	0.120	0.060	9.0	333	3.00	±8.0	150	75	1.0A/250 VAC
MPL-03S-12EUP	0.120	0.060	12.0	250	3.00	±8.0	100	77	1.0A/250 VAC
MPL-03S-15EUP	0.120	0.060	15.0	200	3.00	±5.0	100	78	1.0A/250 VAC
MPL-03S-24EUP	0.120	0.060	24.0	125	3.00	±5.0	100	80	1.0A/250 VAC

- Notes:**
- Operation at no load will not damage the units, however, they may not meet all specifications.
 - The External capacitors (C₁ & C₃) shown in the typical connection diagrams on page 3 are required to meet specified operation.
 - All units will meet EN 55022 (CE/RE) class A with the input circuit shown in the "Typical Connection 1" diagram on page 3. The **MPL03SEUP** will meet class B with the additional filtering shown in the "Typical Connection 2" diagram on page 3. **MPD** offers filter modules that will save on board space and make the input filter design easier. Contact the factory for more information.
 - To meet the requirements of EN 61000-4-3, (10V/m) external filtering (as shown in the "Typical Connection 2" diagram on page 3) is required. This filtering may be added discretely, or by using a filter module from **MPD**. Contact the factory for more information.
 - All units will meet EN 61000-4-4 (±2 kV) with the input circuit shown in the "Typical Connection 1" diagram on page 3. To meet the requirements of EN 61000-4-4 (±4 kV), external components (as shown in the "Typical Connection 2" diagram on page 3) are required. This filtering may be added discretely, or by using a filter module from **MPD**. Contact the factory for more information.
 - All units will meet the requirements of EN 61000-4-5 (±1 kV/±2 kV), with the input circuit shown in the "Typical Connection 2" diagram on page 3. This filtering may be added discretely, or by using a filter module from **MPD**. Contact the factory for more information.
 - All units will meet the requirements of EN 61000-4-6 (3V rms), with the input circuit shown in the "Typical Connection 2" diagram on page 3. This filtering may be added discretely, or by using a filter module from **MPD**. Contact the factory for more information.
 - It is recommended that a fuse be used on the input of a power supply for protection. For the **MPL-03SEUP** series, a 1.0A/250 VAC slow blow should be used.

Derating Curve, Output Power vs Temperature

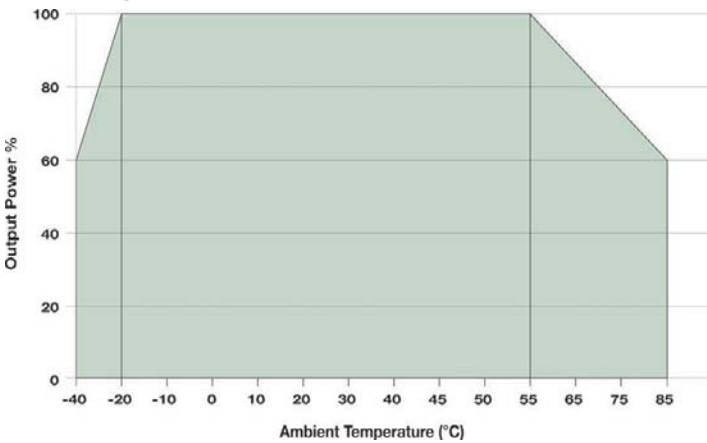

Derating Curve, Output Power vs Input Voltage

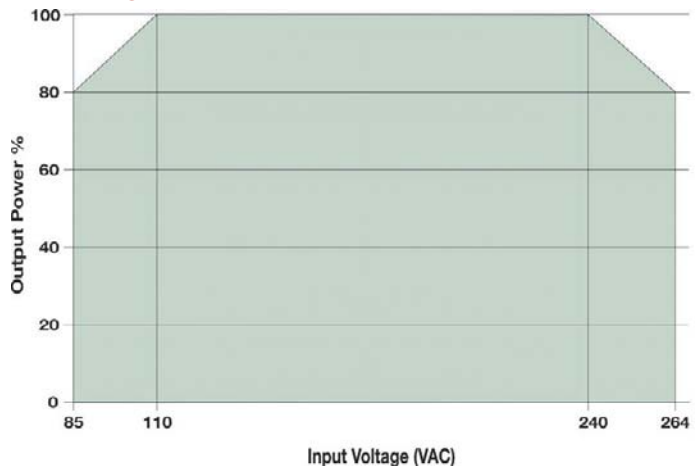

Efficiency vs Input Voltage VAC Input

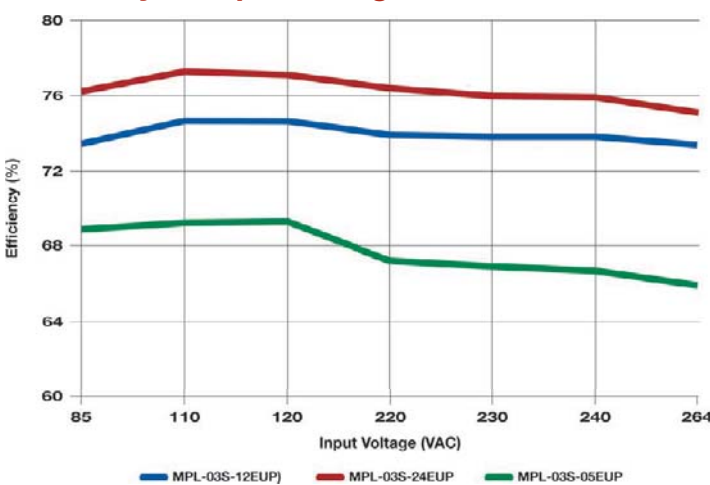

Efficiency vs Input Voltage VDC Input

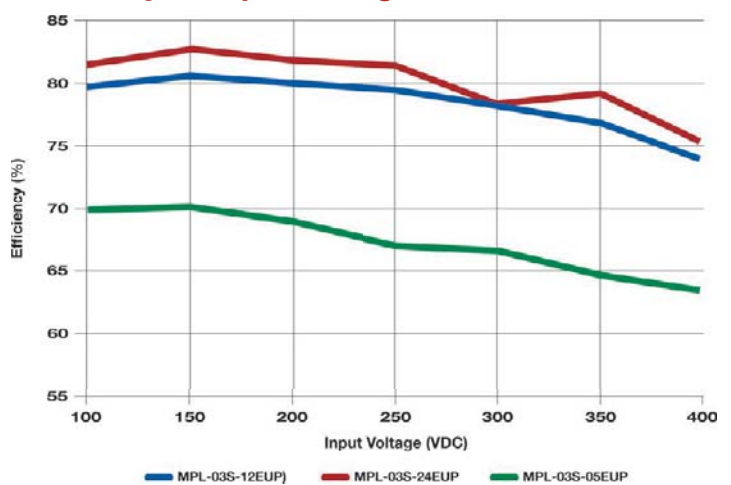

Typical Connection 1

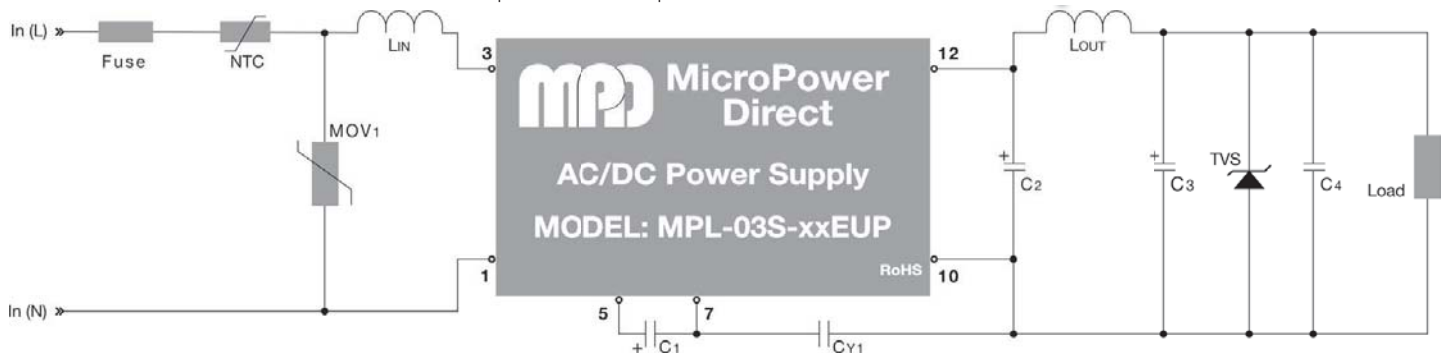

The diagram above illustrates a typical connection of the **MPL-03SEUP** series. With this connection, the unit will meet EN 55022 class A, EN 61000-4-2 ($\pm 4kV$), EN61000-4-4 ($\pm 2kV$), EN 61000-4-8 and EN 61000-4-11. Components C₁ and C₃ are required to meet specified operation limits. The recommended input components are a 5D-9 (NTC), S10K300 (MOV1) and 5 mH (L_{in}). The recommended output component values are given in the table below.

Typical Connection 2: With External EMC Components

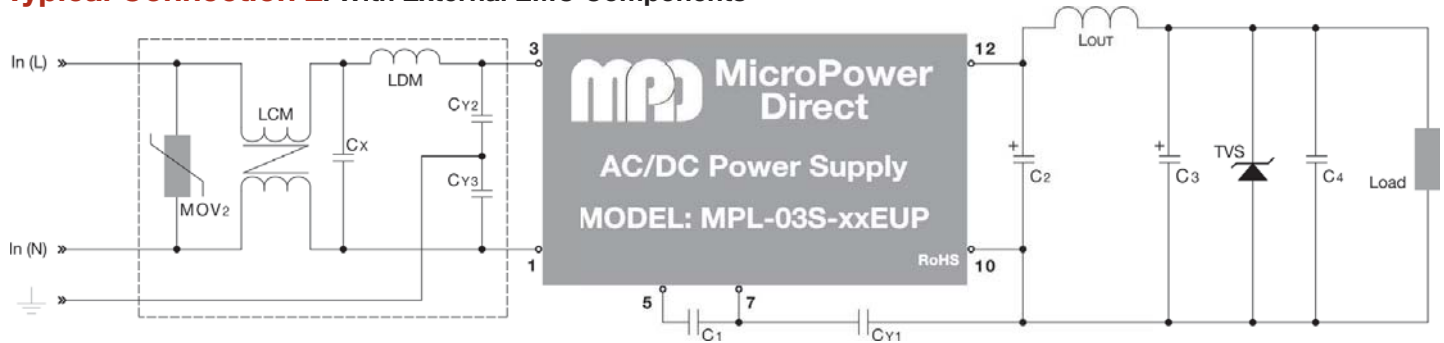

For applications that require meeting higher EMC standards, the circuit shown above is recommended. Some notes on this diagram (starting with the input circuit) are:

1. It is recommended that an external fuse be used. The recommended fuse is 1A/250V.
2. The capacitors C_x and C_{yx} are "safety" capacitors.
3. Capacitor C₁ is a filter component. This capacitor is required to meet specified operation. It should be a high frequency, low ESR electrolytic capacitor. The recommended value is given in the table below.
4. Capacitors C₂ and C₃ are output filter components. Capacitor C₃ is required to meet specified operation. Low ESR, high frequency electrolytic capacitors should be used. The recommended values are given in the table below.
5. Recommended values for components are:

6. The output TVS will help protect system circuitry if power supply fails. A recommended value is given in the table below.
7. Capacitor C₄ is ceramic. This capacitor is used to filter high frequency noise. A recommended value is given in the table below.
8. All of the components within the dotted lines of the input EMC circuit are included in a filter module available from **MPD**. Please contact the factory for more information.

Model Number	External Components											
	MOV	LCM	C _x	LDM	C _{y2} /C _{y3}	C ₁ (Required)	C _{y1}	C ₂	L _{OUT}	C ₃ (Required)	C ₄	TVS
MPL-03S-03EUP	S10k300	3.5 mH	0.1 μF /275 VAC	5 mH	1 nF/400 VAC	22 μF /400V	1 nF/400 VAC	330 μF /25V	2.2 μH	120 μF /25V	0.1 μF /50V	SMBJ7.0A
MPL-03S-05EUP												SMBJ12A
MPL-03S-09EUP												SMBJ20A
MPL-03S-12EUP												
MPL-03S-15EUP												
MPL-03S-24EUP												

Typical Board Layout: With External EMC Components

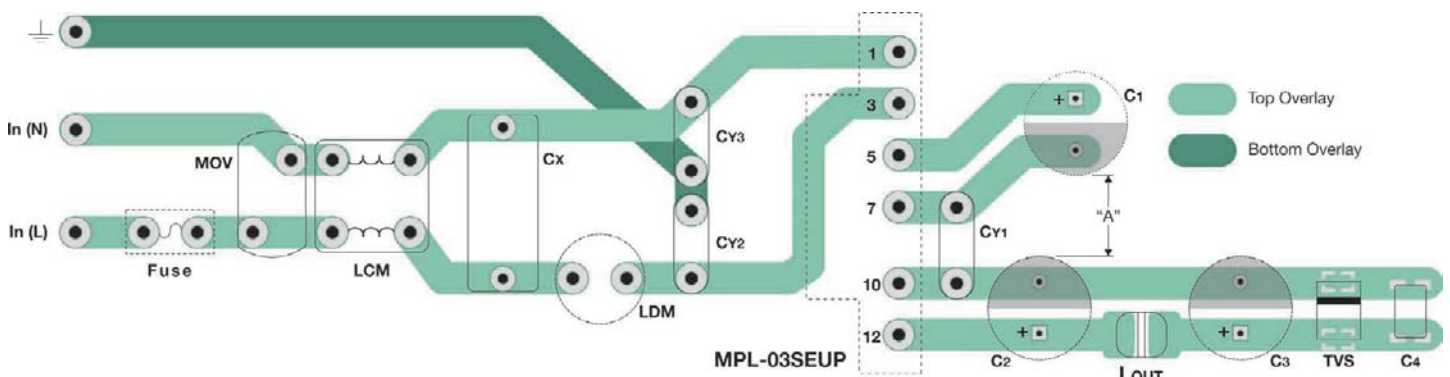

The diagram above shows a typical board layout for the **MPL-03SEUP** with the recommended EMI components shown in the "Typical Connection 2" diagram. Filter modules are available from **MPD**. Contact the factory for more information. To meet safety regulations, the board trace widths should be ≥ 3 mm, the distance between traces should be ≥ 6 mm, and the distance between traces and ground should be ≥ 6 mm. The distance "A" noted on the drawing should be ≥ 6.4 mm.

Mechanical Dimensions

CompuMess Elektronik GmbH · Lise-Meitner-Straße 4 · D-85716 Unterschleißheim
 Telefon (089) 321501-0 · Telefax (089) 321501-11
 info@compumess.de · www.compumess.de · www.netzteile.de

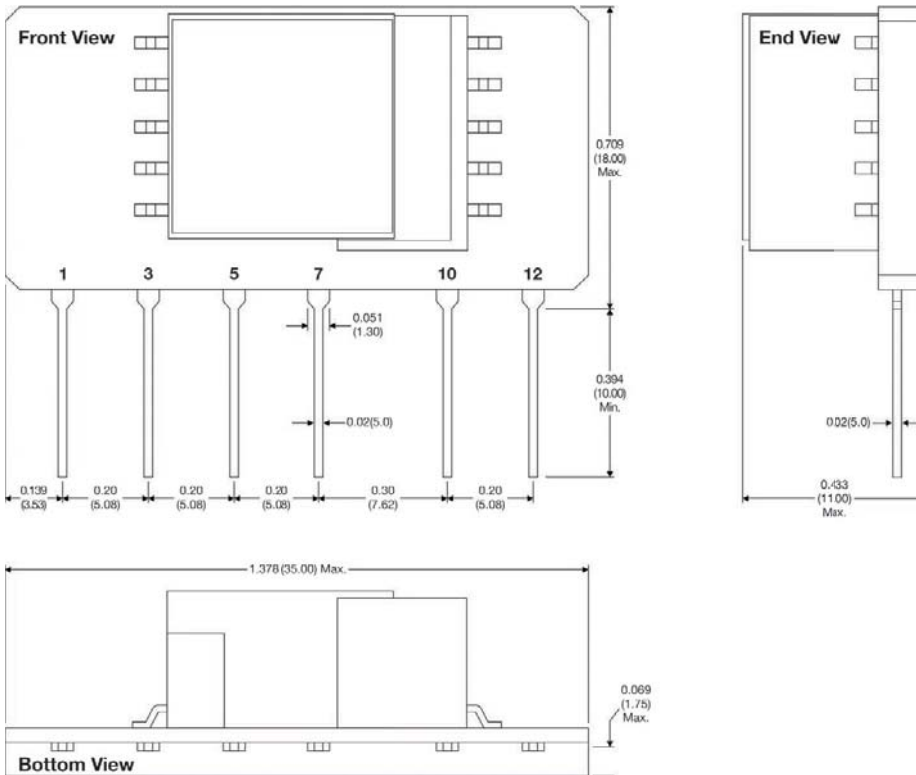

Notes:

- All dimensions are typical in inches (mm)
- Tolerance x.xx = ±0.02 (±0.50)

Pin Connections

Pin	Function
1	AC-Neutral
3	AC-Line
5	+VCAP
7	-VCAP
10	-VOUT
12	+VOUT

Primary/Secondary Separation

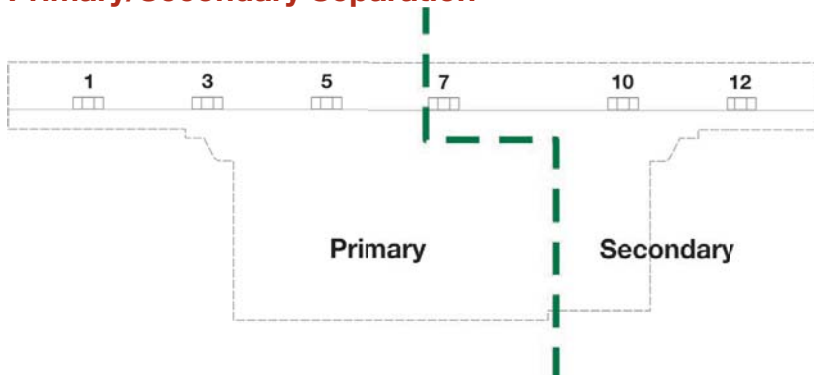

To meet safety requirements, it is required that the separation between any external components in the primary circuit and components in the secondary circuit be ≥ 6.4 mm. The diagram above shows the approximate positioning of the primary/secondary circuits. For more information, please contact the factory.

MicroPower Direct offers a wide range of AC/DC power supplies in miniature SIP packages. Current models include:

MPL-03SE



Key Features:

- 3W Output Power
- Universal 85-264 VAC Input
- EN 60950 Approved
- Meets IEC Safety Class II
- Right Angle Pins Available
- Meets EN 55022 Class A
- >300 kHour MTBF
- **Ultra-Miniature "SIP" Case**

MPL-03SEUP

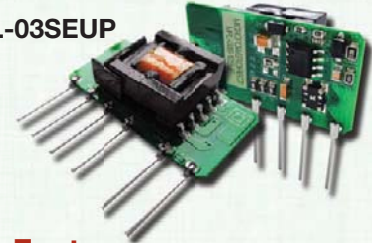

Key Features:

- 3W Output Power
- Universal 85-264 VAC Input
- EN 60950 Pending
- Meets IEC Safety Class II
- Standby Power Consumption <0.5W
- >200 kHour MTBF
- Also Available at 1W and 5W
- **Open, Ultra-Miniature "SIP" Package**

MPL-05SE



Key Features:

- 5W Output Power
- Universal 85-264 VAC Input
- EN 60950 Approved
- Meets IEC Safety Class II
- Right Angle Pins Available
- Meets EN 55022 Class A
- >300 kHour MTBF
- **Ultra-Miniature "SIP" Case**

Find full information on these power products & many others at the **MPD** website:



MicroPower Direct
 We Power Your Success - For Less!