

# POWERVERTER RAIL USB CHARGERS

## 24VDC USB TYPE A & C CHARGER IP65 PROTECTED

### A & C PORT USB CHARGING FOR 24VDC APPLICATIONS CERTIFIED TO EN45545-2, EN50121-3-2 AND EN61373 (ROLLING STOCK)

The widespread use of smartphones and computer tablets has created an increasing need for user accessible, on the move charging systems. The PowerVerter PRPWp Railway Range is specifically designed to meet all requirements for rolling stock applications. These units can easily be installed into seat backs (space permitting), under the seat, directly into carriage walls, or tabletops using the suitable mounting pods available.

These chargers are available in both standard (secured from the rear with a nut) or front fitting, secured by three screws, covered with a discreet cover ring. Ingress protection is to IP65 (not connectors).

For systems already galvanically isolated, the PRPWp can be connected directly to the electrical system at 24V. These units have been approved to EN50155.

Alfatronix products have been tested to Rail Fire EN45545-2.

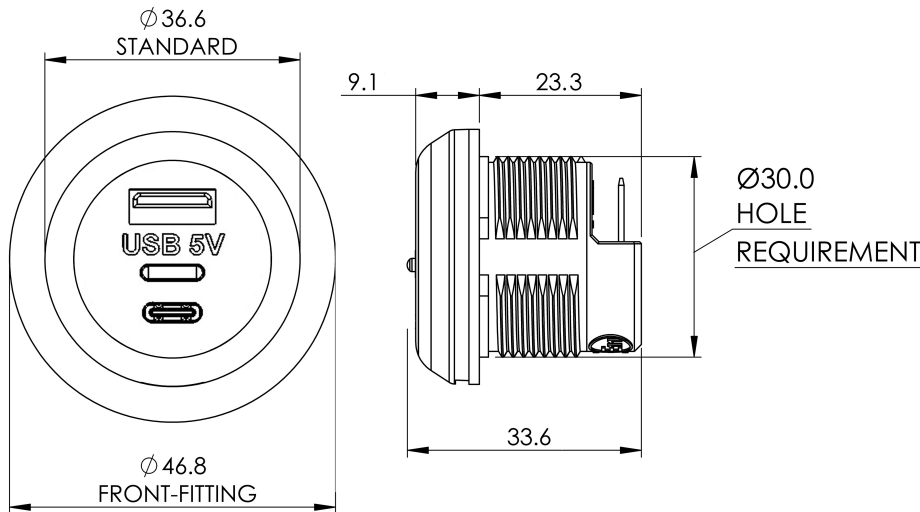

All dimensions in mm.

### THE RANGE

All units are installed through a 30mm hole. Standard format units are retained by a rear nut while the front fit versions include a bezel with tamperproof cover ring. Input power is by way of two 6.3mm push-on flat fit automotive terminals.

Electronically the designs include reverse polarity protection and the output withstands short circuit current and will return back to full operation when the short is removed.

### SAFETY

A requirement of the USB standard is that the metal cage around the USB plugs and sockets is connected to ground (zero volts). If a USB charger is to be used in an application with a positive ground, i.e. battery/supply positive terminal is connected to the vehicle chassis, then there is a risk that the exposed metal cage of any USB cable could come in contact

with the positive connected chassis, causing uncontrolled heating of the USB cable and USB charger and potentially creating a hazard.

In positive ground applications, the use of an isolated Alfatronix Converter is required to be installed between the positive ground supply and the input of the USB charger. Please refer to the PRi DC-DC datasheet.

### WARRANTY

The PRPWp range of chargers are manufactured using rugged components to provide years of service in demanding commercial environments and are covered by a three year return to base guarantee.



PRPWp-CC, standard fit CC USB charger secured into place with locking nut.

The PRPWp range has the following key benefits:

- Both type-A and type-C outputs
- Apple and Android compatible
- Carriage wall, seat back or underseat and tabletop pod configurations
- LED output indicator
- IP65 ingress protection
- CE and UKCA marked



PRPWp-ACFf, front fitting version can be screwed in place from the front, then covered with the attractive ring to avoid tampering.



## POWERVERTER RAIL USB CHARGERS

Part Number	Description	Dimensions (mm)	Weight
PRPWp-AC	USB 'A' & 'C' Dual output rugged, IP65 24-5V, 3.6A	Ø37 x 34; Hole Ø30; Rearspace typ.36	29g
PRPWp-C	USB 'C' Single output rugged, IP65 24-5V, 3.0A	Ø37 x 34; Hole Ø30; Rearspace typ.36	23g
PRPWp-CC	USB 'C' & 'C' Dual output rugged, IP65 24-5V, 3.0A	Ø37 x 34; Hole Ø30; Rearspace typ.36	24g

**For front fit versions, please add the suffix Ff, e.g. PRPWp-AAFf, PVPWp-ACFf etc. The detachable ring in both standard and front fit format can be customised for branding and advertising purposes. Please ask our sales team.**

Accessories			
USB-POD	Under-seat mounting pod for USB chargers	W 60, H 52, D 80	69g
USB-TPOD	Table mounting pod for 2x USB chargers	W 103, H 44.5, D 88	73g
USB-WPOD	Wall mounting pods for USB chargers	W 60.5, H 75.9, D 25.6	22g

**The USB 'A' & 'C' dual output or 'C' single and dual outputs can also be installed with the USB-POD, USB-TPOD or USB-WPOD. Please ask our sales team.**

## TECHNICAL DATA

Input voltage range	16-32Vdc
Output voltage	5.2Vdc +/- 0.2V
Max Output Power	Dual A & A: 3.0A, Single A: 2.1A, Dual A & C: 3.6A, Single C: 3.0A, Dual C: 3.0A
Application	Charging of USB devices including Apple and Android
Transient voltage protection	EN50121-3-2 to EN61000-4-4
Electrostatic discharge	EN50121-3-2 to EN61000-4-2
RF Immunity	Conducted: EN50121-3-2 to EN61000-4-6, Radiated to EN61000-4-3
RF Emissions	EN50121-3-2 to EN55016-2-3 and EN55016-2-1
Surges	EN50121-3-2 to EN61000-4-5
Vibration, Shock, Impact	EN61373
Output noise	<50mV pk-pk
Off load current (quiescent current)	<2.5mA
Isolation	Non-isolated >400Vrms between casing and terminals
Power conversion efficiency	90%
Operating temperature	-25°C to +55°C to meet this specification table
Storage temperature	-40°C to +100°C
Operating humidity	95% max., non-condensing
Casework	Dark grey polycarbonate body, contrasting trim ring
Connections	Input: 6.3mm push-on flat blade connectors Output: USB type-A socket, USB type-C socket
Output indicator	Blue LED output indication
Mounting method	30mm diameter hole, with rear nut or front fit bezel
Safe area protection:	Over Current Limited by current sensing circuit
	Over heat Limited by temperature sensing circuit
	Overvoltage and Undervoltage Limited by sensing circuit
	Reverse Polarity Protected by sensing circuit
	Transients Protected by filters and rugged component selection
	Catastrophic protection Internal fuse (external fusing recommended)
Approvals	93/68/EEC The CE marking directive 2014/30/EU The general EMC directive (UKCA 2016 No 1091) Railway Standards to EN50155 (EN50121-3-2), EN45545-2 and EN61373.
Markings	CE and UKCA
IP Rating	IP65 (USB connector excluded). Cleaning: wipe with damp cloth, do not spray.